

RiB Magnetic Level Gauges provides clear, high clarity indication of liquid level. Magnetic Level Gauges are principally designed as an alternative to glass level gauges. MLGs are now widely used in all industries as they avoid direct contact with indicator system; it eliminates need of glass for direct level indication and prevents chemical spillage due to breakage of glass.

Features

- Magnetic level gauge applicable upto 100 kg / cm² and upto 300 deg cent
- Cryo applications upto - 196 deg cent
- Jacketed design applicable
- For applicability in critical, acidic, cryo and high temperature zone
- NACE service compatibility applicable
- Heat tracing available
- Viscous media (max upto 380 cst and upto 100 deg cent) besides other acidic, non acidic, steam water media
- CE applicability
- Device fully compatible for conductive and non conductive media
- Special float design to enable to meet low critical specific gravity
- Design applicability test with special media available
- Applicable for refinery, petrochemical, chemical, power, radioactive, fertilizer, food, pharma, metal industry applications
- CE approved switches available
- Versions available with analog and digital (HART) and FIELDBUS transmitters fully integrated with the system for level gauge and transmitter
- CE approved and applicable for HART and analog transmitters available

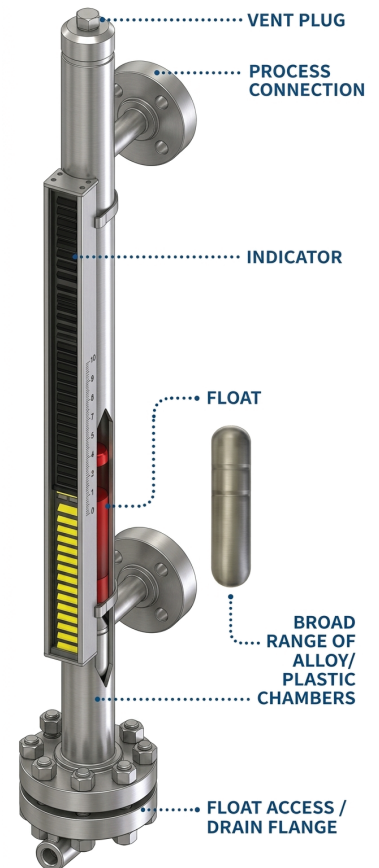

Concept and Principle of operation

Magnetic Level Gauges operates on the principle of magnetic field coupling to provide fluid level information. Float chamber is typically constructed having process connections that matches to the vessel connections. Float size and weight is determined by the process fluid, pressure, temperature and the specific gravity of the process fluid. Float contains magnets to provide 360 magnetic flux field.

Magnetic Level Gauge - Flapper Indicator system consists of bicolour rollers equipped with magnets mounted on rail inside the housing. As the level starts rising or falling magnetic float also travels with liquid level in non magnetic chamber. The magnetic interaction between magnets in float and bicolour rollers causes each roller to rotate 180°.

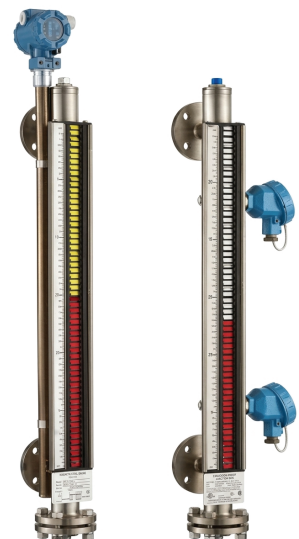

Technical Specifications: Table-1 Technical Data

Parameter	Specification
Type of Gauge	Magnetic Level Gauge - MLG
Mounting Orientation	Top Mounted / Side Mounted
Pressure	Upto 100 kg/cm ²
Temperature	Upto 300°C
CCD	Max. upto 7000mm
Liquid Chamber	In forged construction: SS304, SS304L, SS316, SS316L, PP, Titanium, Inconel 600, Hastelloy C. Other on request subject to pressure & temperature condition
MOC of Float	In forged construction: SS304, SS304L, SS316, SS316L, PP, Titanium, Inconel 600, Hastelloy C
Gasket	CAF, PTFE, Grafoil with SS pregated
Fastener	CS Plated, SS
Scale	Aluminium, Aluminium anticorrosion powder coated and SS engraved in mm
Indicating System	Bicolour flapper in ABS/ Aluminium/ SS with 4mm length & 0.25 mm thickness with aligned magnets
Protection box for bicolour flapper & follower type	In mild steel, Aluminium, SS304, SS316 base on the requirements of atmospheric condition
Process Connection	Flanged
Vent	½" Plugged / ½" Needle Valve / ½" Ball Valve / ½" Globe Valve / ½" Gate Valve
Drain	½" Plugged / ½" Needle Valve / ½" Ball Valve / ½" Globe Valve / ½" Gate Valve
Specific gravity	Please specify
Limit Switch Assembly	Snap acting 1 SPDT Microswitch, 5A, 230VAC
Switch Housing	Die Cast Aluminium Weatherproof to IP-67 Die Cast Aluminium Explosionproof suitable for Gr. IIA, IIB Die Cast Aluminium Explosionproof suitable for Gr. IIC
Cable Entry	1 no / 2 nos. of 3/4" ET(F)
Optional	Still well for top mounted construction

Construction and Dimensional Cross Sectional Overview

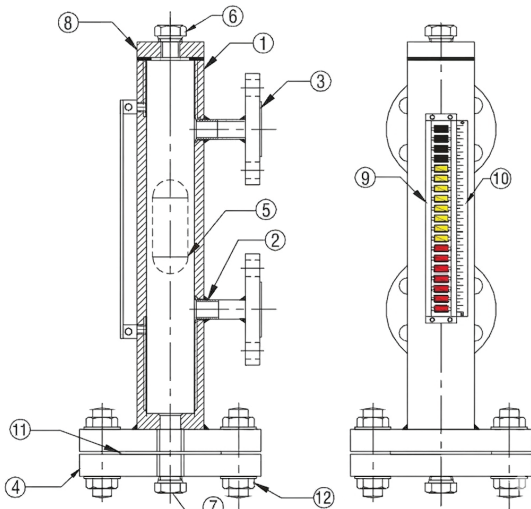

1. Liquid Chamber
2. Nozzle
3. Process Flange
4. Bottom Flange
5. Magnetic Float
6. Vent Plug
7. Drain Valve
8. Top Cap
9. Indicating System
10. Scale
11. Gasket
12. Fastener

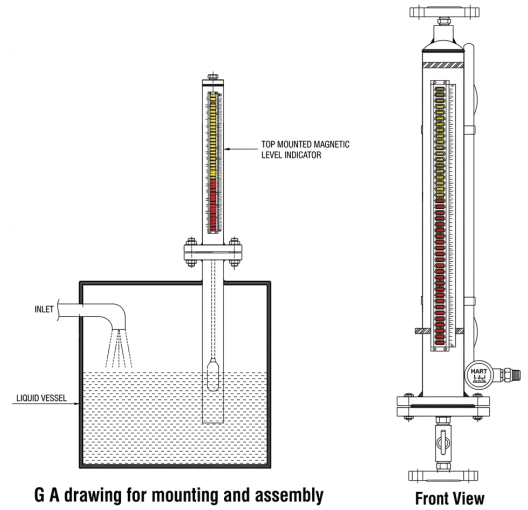

G A drawing for mounting and assembly

Front View

With HART transmitter mounted on a 900# application gauge at CCD of 4000 mm with magnetostrictive principle for chemical plant application.

Ordering Information

MLG SM-1000-F03-ZE-VD-XD-VW-XW-QU-RU-SO-LX-Z



Orientation of Process Connection

MT	Top Mounted
SM	Side Mounted

Centre to Centre Distance

1000	Indicate the required Centre to Centre Distance in mm
------	---

Process Connection

Flanged Connection			
F01	1/2", 150# RF	F13	2", 300# RF
F02	3/4", 150# RF	F17	1/2", 600# RF
F03	1", 150# RF	F19	1", 600# RF
F04	1.5", 150# RF	F20	1.5", 600# RF
F05	2", 150# RF	F21	2", 600# RF
F09	1/2", 300# RF	F48	1", 900# RTJ
F10	3/4", 300# RF	F49	1.5", 900# RTJ
F11		F50	2", 900# RTJ
F12	1.5", 300# RF	XX	Any Other*

MOC of Connection

ZC	SS 304	ZK	Monel 500
ZD	SS 304L	ZL	Titanium
ZE	SS 316	ZM	Hastelloy B
ZF	SS 316L	ZN	Hastelloy C
ZI	PP	ZO	Inconel 600
XX	Any Other*		

MOC of Chamber

VB	SS 304	VH	Monel 500
VC	SS 304L	VI	Titanium
VD	SS 316	VJ	Hastelloy 'B'
VE	SS 316L	VK	Hastelloy 'C'
VF	PP	VL	Inconel 600
XX	Any Other*		

MOC of Float

XB	SS 304	XH	Monel 500
XC	SS 304L	XI	Titanium
XD	SS 316	XJ	Hastelloy 'B'
XE	SS 316L	XK	Hastelloy 'C'
XF	PP	XL	Inconel 600
XX	Any Other*		

Optional

LX	Limit Switch with Die cast Aluminium Weatherproof IP-67
LY	Limit Switch with Die cast Aluminium Flameproof suitable to Gr. IIA/ IIB
LZ	Limit Switch with Die cast Aluminium Flameproof suitable to Gr. IIC
LT	4-20 mA OUT PUT
Z	NIL

Calibration Scale

SO	Aluminium with Powder coat
SP	Aluminium
SQ	SS304
SR	SS316
SS	Acrylic

Drain

RU	1/2" NPT (F), Plug	RX	1/2" Ball Valve
RV	3/4" NPT (F), Plug	RY	1/2" Gate Valve
RW	1/2" Needle Valve	RZ	1/2" Globe Valve

Vent

QU	1/2" NPT (F), Plug	WX	1/2" Ball Valve
QV	3/4" NPT (F), Plug	QY	1/2" Gate Valve
QW	1/2" Needle Valve	QZ	1/2" Globe Valve

Gasket

XW	C.A.F.
XX	P.T.F.E.
XY	Graphoil

Fasteners

VV	ASTM A 193 Gr. B7 / ASTM A 194 Gr. 2H
VW	SS
VX	Anodized Aluminium
VY	CS Plated

Note: * Please consult factory